

---

## MX400SE -- Gooseneck Microphones

---

### General Description

Shure Microflex® MX400SE Series microphones are miniature gooseneck-mounted electret condenser microphones designed primarily for speech and vocal pickup. Their high sensitivity and broad frequency range make them suitable for recording, as well as sound reinforcement applications.

The MX400SE series can be screwed onto a mic stand or the supplied 5/8 in. 27-threaded flange. They can be easily changed from side exit to bottom exit to conceal the cabling. All models include an in-line preamplifier, a 3.66 m (12 ft.) cable.

MX400 microphones are available with 305 mm (12 in.) or 457 mm (18 in.) goosenecks, with or without a mute switch. They are available in supercardioid, cardioid and omnidirectional polar patterns.

- "S" models include a mute button and LED.
- "D" models include a desktop base with programmable mute button and LED and logic input and output.
- "SE" models feature a surface mount flange with side-exit cable.

The polar pattern of the included cartridge is indicated by a model number suffix:

**/C** Cardioid

**/S** Supercardioid

**/O** Omnidirectional

**/N** Cartridge not included

---

### Interchangeable Cartridges

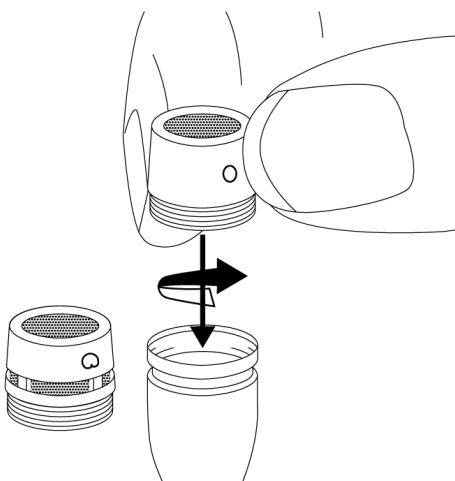

Microflex microphones use interchangeable cartridges that allow you to choose the polar pattern for different installations.

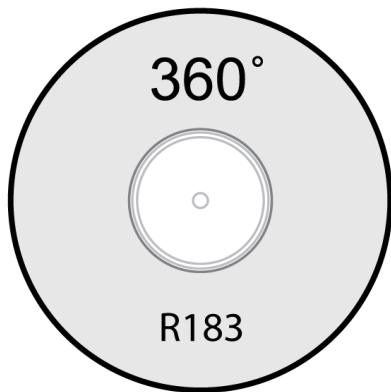

Omnidirectional

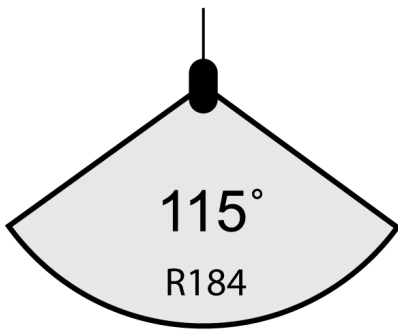

Supercardioid

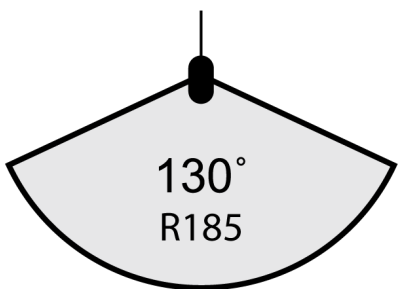

Cardioid

---

## Snap-Fit Windscreen

- Snap into the groove below the cartridge.
- To remove, spread the gap with a screwdriver or thumbnail.
- Provides 30 dB of "pop" protection.

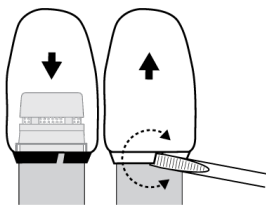

## Preamp Gain

If necessary, the preamplifier gain can be reduced by 12 dB. Contact an authorized Shure service center for information.

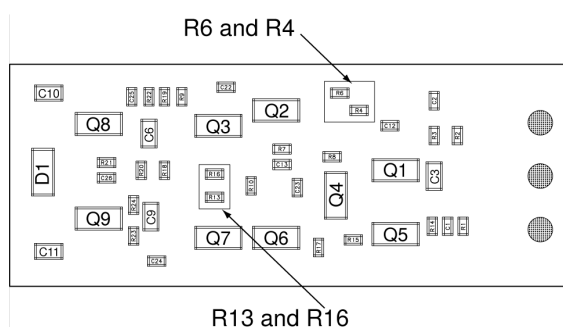
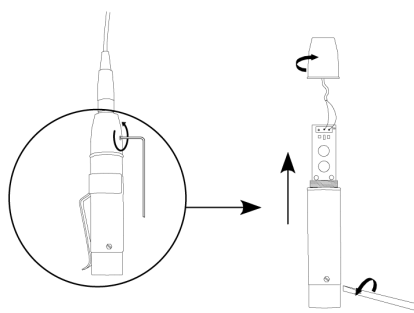

GAIN SETTING		
	12 dB	0 dB
R6	10k	0 $\Omega$
R4	10k	20k
R16	0 $\Omega$	10M
R13	DNP	301 $\Omega$

## RFI Filtering

**Important:** Microphones must be used with the RK100PK or RK202PK plate-mounted preamp to optimize RF immunity.

## Microphone Placement

- Aim the microphone toward the desired source, such as the talker.
- Aim it away from any unwanted source, such as a loudspeaker.
- Place the microphone within 15 to 30cm (6 to 12 in.) of the desired sound source.
- Always use the supplied windscreen or optional metal windscreen to control breath noise.
- If four or more microphones will be open at the same time, use of an automatic mixer, such as the Shure SCM810 or SCM410, is recommended.

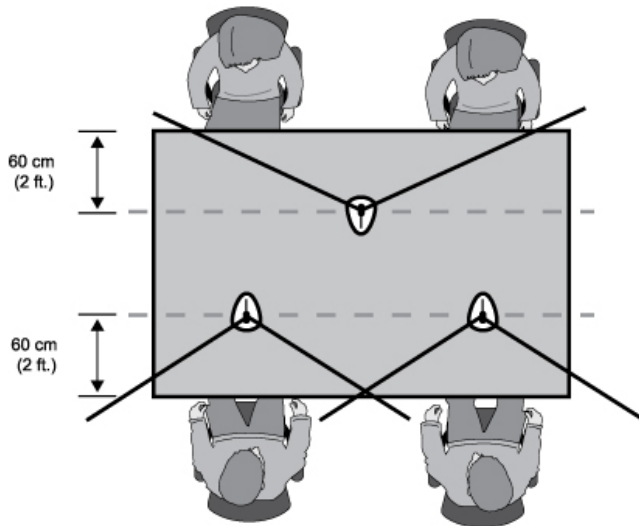

## Permanent Installation

### Changing from Side Exit to Bottom Exit

Do not cut the cable to reroute. This will compromise RF immunity.

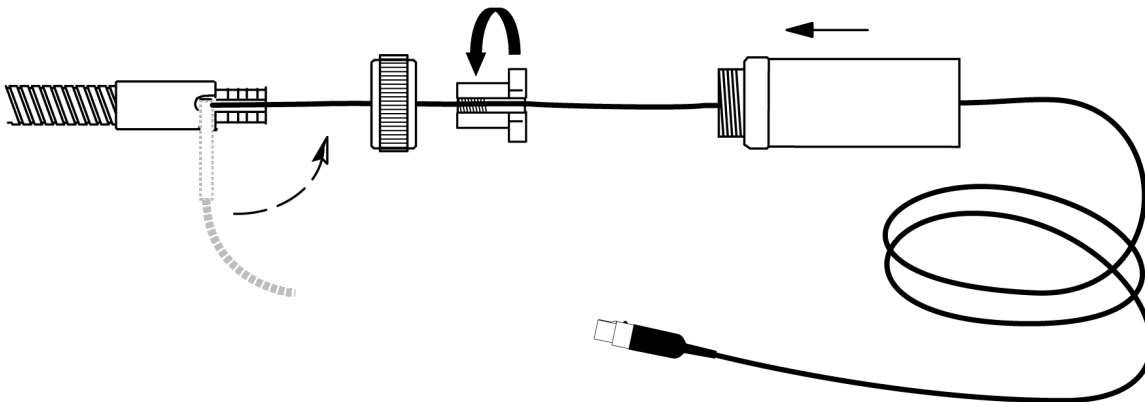

Mount the microphone using one of the following methods.

### Flange

Slip the mounting flange retaining ring over the bottom of the preamplifier and slide it up until it is flush to the bottom of the flange. Then press the ring firmly into place.

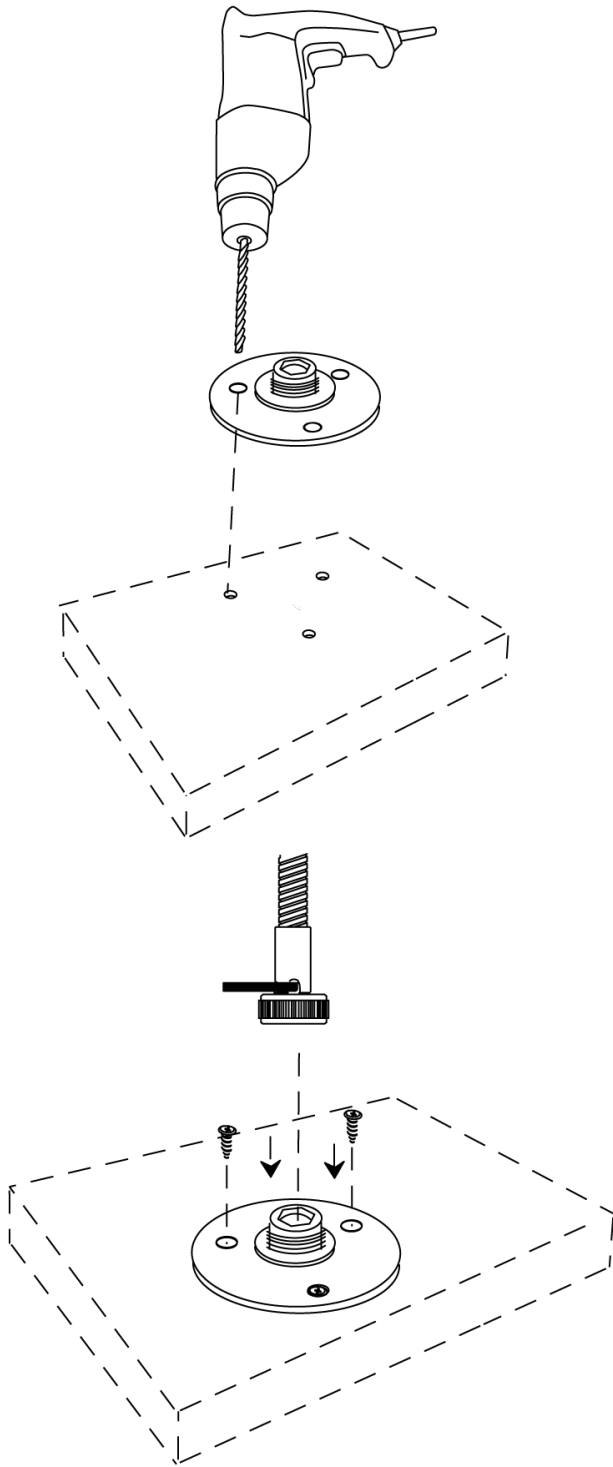

## Shock Mount

1. Drill a 44mm(1-3/4 in.) diameter hole in desired mounting surface.
2. Mark and drill starter holes for screws, using shock mount as a template.
3. Secure shock mount to mounting surface with screws.
4. Thread the supplied adapter onto the MX400SE microphone before inserting it into the shock mount.

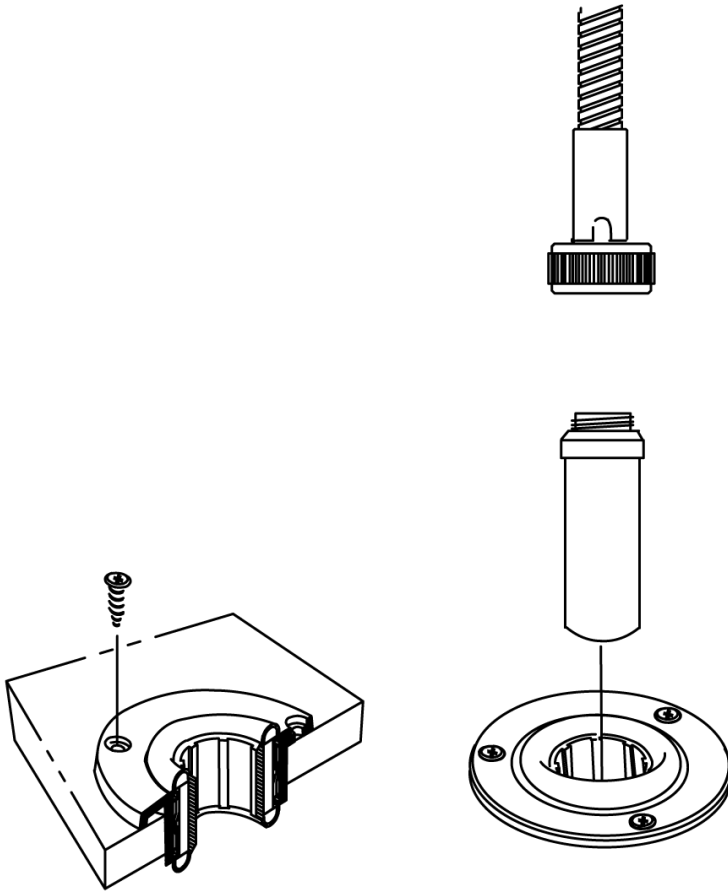

## Specifications

### Cartridge Type

Electret Condenser

### Frequency Response

50 to 17000 Hz

### Polar Pattern

MX412SE/C, MX418SE/C	Cardioid
MX412SE/S, MX418SE/S	Supercardioid

### Output Impedance

180  $\Omega$

### Output Configuration

Active Balanced

**Sensitivity**

@ 1 kHz, open circuit voltage

Cardioid	-35 dBV/Pa(18 mV)
Supercardioid	-34 dBV/Pa(21 mV)

1 Pa=94 dB SPL

**Maximum SPL**

1 kHz at 1% THD, 1 k $\Omega$  load

Cardioid	124 dB
Supercardioid	123 dB

**Equivalent Output Noise**

A-weighted

Cardioid	28 dB SPL
Supercardioid	27 dB SPL

**Signal-to-Noise Ratio**

Ref. 94 dB SPL at 1 kHz

Cardioid	66 dB
Supercardioid	68 dB

**Dynamic Range**

1 k $\Omega$  load, @ 1 kHz

96 dB

**Common Mode Rejection**

10 Hz to 100 kHz

45 dB, minimum

**Preamp Output Clipping Level**

at 1% THD

-6 dBV (0.5 V)

**Polarity**

Positive sound pressure on diaphragm produces positive voltage on pin 2 relative to pin 3 of output XLR connector

**Environmental Conditions**

Operating Temperature	-18–57°C (0–135°F)
Storage Temperature	-29–74°C (-20–165°F)
Relative Humidity	0–95%

**Power Requirements**

11–52 V DC, 2.0 mA

**Cable**

3.0 m (10 ft) , attached



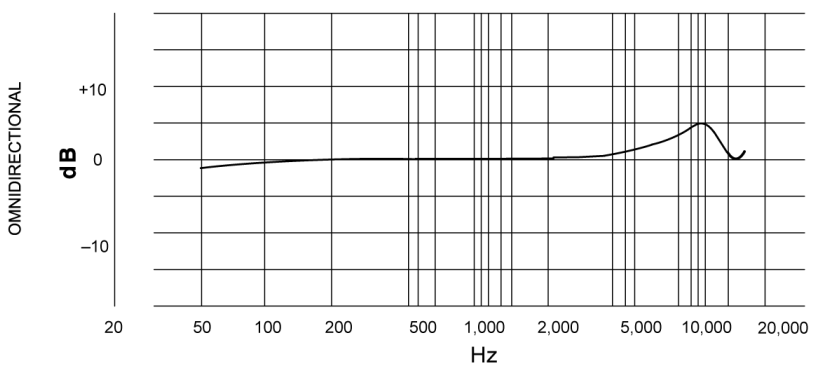
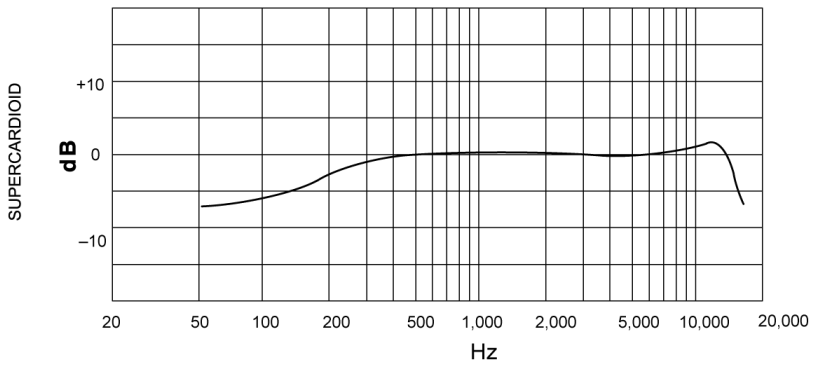
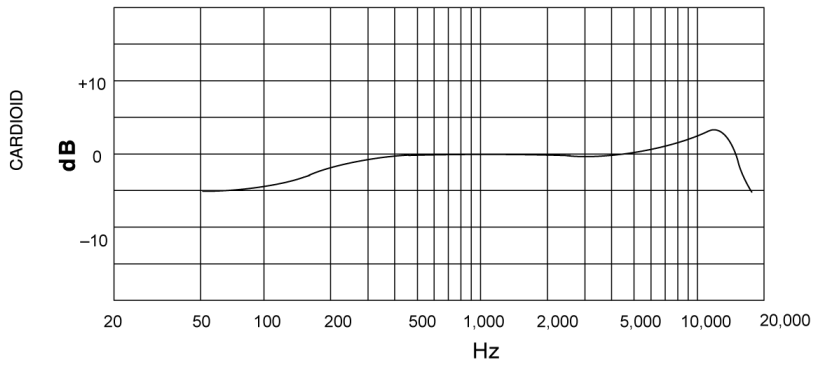

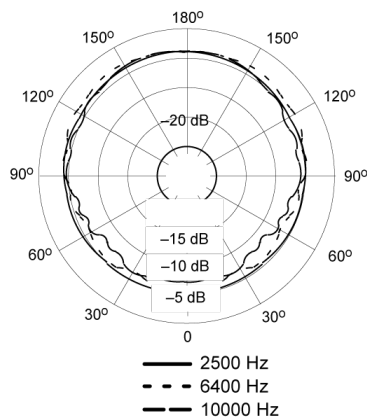
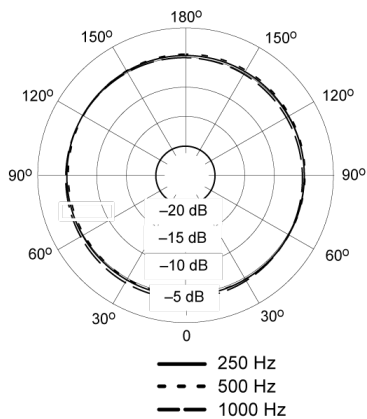
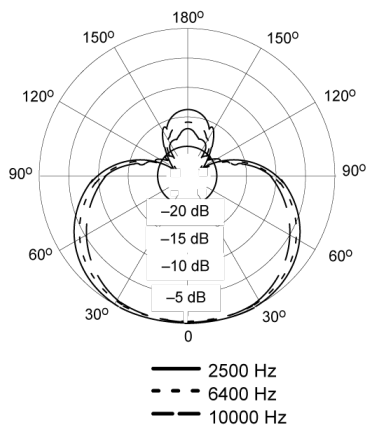
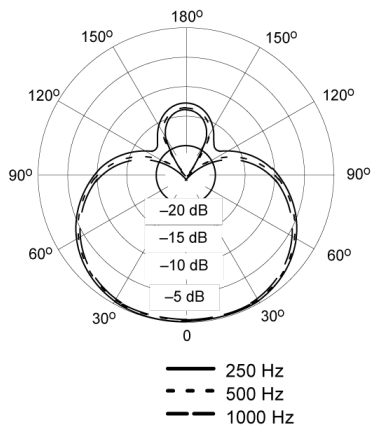
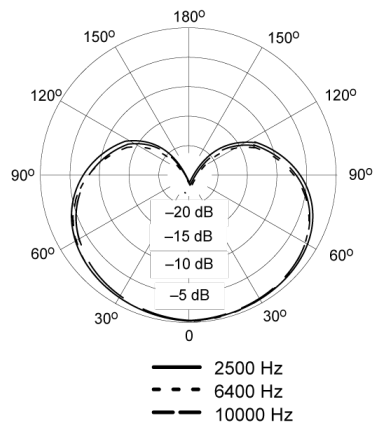
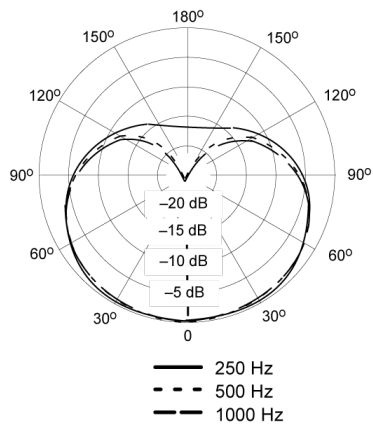

## Certifications

Meets essential requirements of all applicable European Directives.

Eligible for CE marking.

The CE Declaration of Conformity can be obtained from Shure Incorporated or any of its European representatives. For contact information please visit [www.shure.com](http://www.shure.com)

The CE Declaration of Conformity can be obtained from: [www.shure.com/europe/compliance](http://www.shure.com/europe/compliance)

Authorized European representative:

Shure Europe GmbH

Headquarters Europe, Middle East & Africa

Department: EMEA Approval

Jakob-Dieffenbacher-Str. 12

75031 Eppingen, Germany

Phone: +49-7262-92 49 0

Fax: +49-7262-92 49 11 4

Email: [info@shure.de](mailto:info@shure.de)